

LXC-120C

Technical Data

 Art. No.
11148664

Sensor Graph: Relative Response

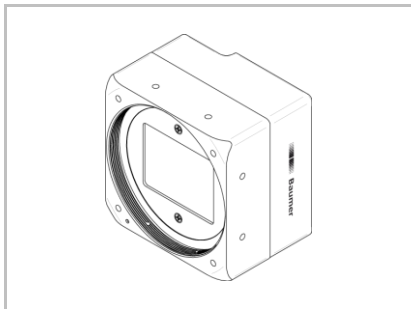
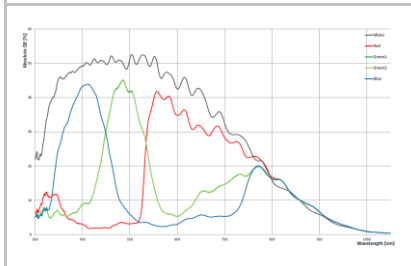

Digital Output: High Active

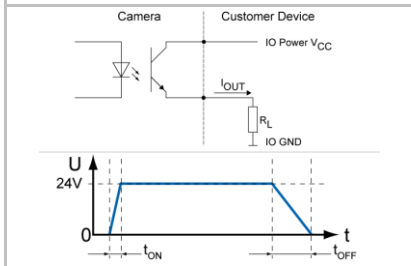

Digital Output: Low Active

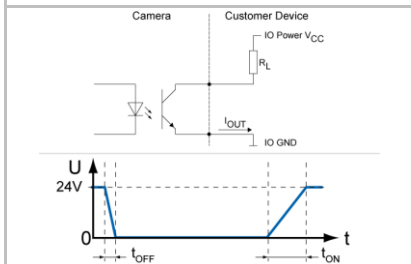

Digital Color Matrix Camera, Camera Link Full

Sensor Information

Model Name	CMOSIS CMV12000
Type	APS-C progressive scan CMOS
Shutter	Global
Native Resolution	4096 x 3072 pixels
Scan Area	22.528 mm x 16.896 mm
Pixel Size	5.5 μm x 5.5 μm

Data Quality

@ 20 °C, gain = 1, exposure time = 4 msec

Readout Noise (σ)	0.5 LSB @ 8 bit (typical)
Dynamic Range	56.5 dB (typical)

Acquisition Formats

Image Formats	Format	Resolution	Frame Rate	t_{readout}
	Full Frame	4096 x 3072	63 fps	15,9 msec
Pixel Formats	BayerGB8, BayerGB10			
Partial Scan	True Partial Scan, Region of Interest (ROI) arbitrary, up to 8 regions			

Image Pre-Processing

Analog Controls	Exposure Time (16 μsec ... 1 sec Step Size 1 μsec) Gain (0 ... 12 dB), Offset (0 ... 63 LSB 10 bit)
Gamma Correction	Gamma (0.1 ... 2 available if LUT is enabled)
LUT	Luminance (12 bit)
Color Models	No (Raw Bayer data only)
Color Tolerance	-
Color Processing	No (Raw Bayer data only)
Color Adjustment	White Balance (manual & one push)
Binning	-
Decimation	1 or 2 (Horizontal and Vertical)
Image Flipping	Horizontal, vertical
Defect Pixel Correction	via Defect Pixel List with up to 511 Pixel Coordinates

Process Synchronization

Modes	Free Running, Trigger
Free Running	Continuous or Adjustable Acquisition Frame Rate (0.01 ... 14705 Hz)
Trigger Sources	Hardware, Software, FrameGrabber, All or Off
Trigger Delay	0 ... 2 sec, Tracking and buffering of up to 512 triggers
Sequencer Characteristics	up to 128 sets of parameters, up to 65536 loop passes, up to 65536 repetitions of sets of parameters, up to 65536 images per trigger event
Sequencer Parameters	Exposure Time, Gain Factor, Output Line, ROI Offset x, ROI offset y
External Flash Sync	via Exposure Active $t_{\text{delay flash}} \leq 3 \mu\text{sec}$, $t_{\text{duration}} = t_{\text{exposure}} + 18 \mu\text{sec}$

Digital I/Os

Lines	Input: Line 0, Line 1 (Frame grabber CC1) Output: Line 2
Circuit Times	Output: $t_{\text{ON}} = \text{typ. } 2 \mu\text{sec}$ $t_{\text{OFF}} = \text{typ. } 30 \mu\text{sec}$
Output Sources	Off, ExposureActive, ReadoutActive, FrameActive, TriggerReady, TriggerOverlapped, TriggerSkipped, Line 0, UserOutput{1}, Timer{1}Active, SequencerOutput{0}
Line Debouncer	Low and high signal separately selectable Debouncing Time 0 ... 5 msec, Step Size: 1 μsec

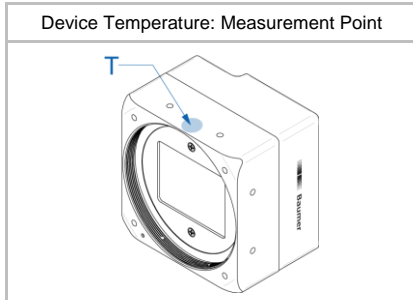
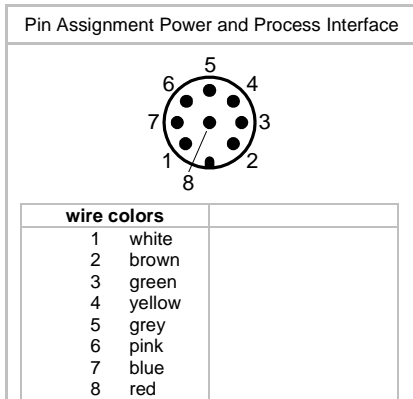
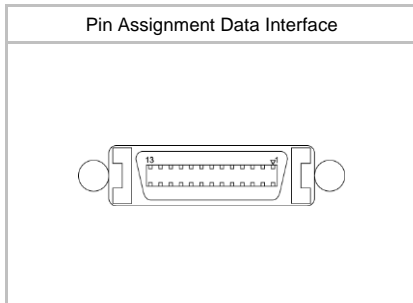
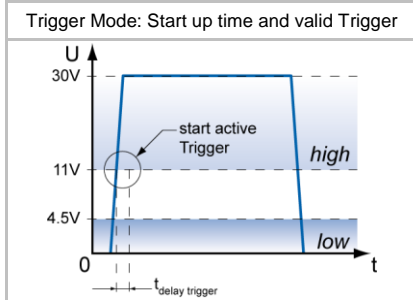
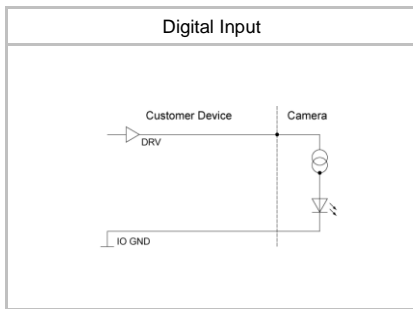

Interfaces and Connectors

Data Interface (1/2)	Camera Link: Connector:	Transfer Rate up to 10 tap / 85 MHz Camera Link SDR26 Mini screw lock type
	Pin Assignment:	See user manual
Power and Process Interface	Connector: Assignment:	SACC-DSI-M8FS-8CON-M10-L180 SH 1 – NC 5 – IO Power VCC 2 – Power VCC 6 – OUT1 (line2) 3 – IN1 (line0) 7 – GND 4 – IO GND 8 – NC

Mechanical Data

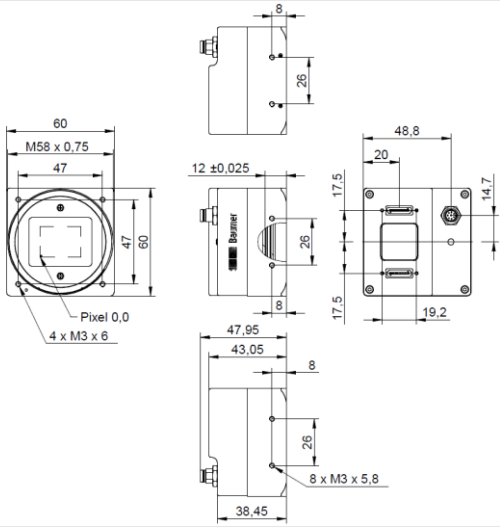
Housing	Aluminum, IP40
Dimensions	
Weight	235 g (M58-Mount), 335 g (F-Mount), 285 g (M42-Mount), 275 g (C-Mount)

Optical Data

Lens Mount	M58-Mount, via optional adapters F-/M42-/C-Mount
Optical Filter	UV/IR Cut

Electrical Data

Power Supply (ext.)	VCC: 12 ... 24 V DC ± 20% I: 270 ... 540 mA
Power over Camera Link (PoCL)	VCC: 12 V DC ± 20% I: 540 mA
Power Consumption	approx. 6,5 W @ 24 VDC and 63 fps approx. 6,5 W @ 12 VDC (PoCL) and 63 fps
Digital Input	U _{IN(low)} : 0.0 ... 4.5 VDC U _{IN(high)} : 11.0 ... 30.0 VDC I _{IN} : 6.0 ... 10 mA min. Impulse Length: 2.0 µsec Trigger Delay out of treadout: 4.0 µsec max. Trigger Delay during treadout: 30.0 µsec
Digital Output	U _{EXT} : 5 ... 30 V DC I _{OUT} : max. 50 mA



LED Signalling

Camera LED	Green on	Power on
	Red on	Error
	Red blinking	Warning
	Yellow	Readout active

Environmental Data

Storage Temperature	-10 °C bis +70 °C
Operating Temperature	+5°C ... +65°C
Device Temperature	T _{max} = 65 °C @ Measurement Point
Humidity	10 % ... 90 % non-condensing
Conformity	RoHS, REACH, CE



Camera Link Data Interface

Standard	v. 2.1		
Pixel Formats	Base	1X1-1Y	BayerGB8, BayerGB10
	Base	1X2-1Y	BayerGB8, BayerGB10
	Base	1X3-1Y	BayerGB8
	Medium	1X3-1Y	BayerGB10
	Medium	1X4-1Y	BayerGB8, BayerGB10
	Full	1X8-1Y	BayerGB8
	EightyBit	1X8-1Y	BayerGB10
	EightyBit	1X10-1Y	BayerGB8
Pixel Clock	40 - 85 MHz		

GenCP Features

(in compliance with GenCP 1.0)

Events Transmission via Asynchronous Message Channel	EventLost, EventDiscarded, Line{0,1,2,3}RisingEdge, Line{0,1,2,3}FallingEdge, ExposureStart, ExposureEnd, FrameStart, FrameEnd, TriggerReady, TriggerOverlapped, TriggerSkipped, Timer{1,2,3}End
---	--

GenCam™ Features

(in compliance with SFNC 2.1.0)

Timer	Timer Selector: Timer 1 ... 3 TimerTriggerSource: Off, Line0, Software, Action1, TriggerSkipped ExposureStart, ExposureEnd, FrameStart, FrameEnd, TimerDelay: 0 µsec ... 2 sec, Step Size: 1 µsec TimerDuration: 10 µsec ... 2 sec, Step Size: 1 µsec
User Sets	Factory Settings: Default (read only) Freely Programmable: UserSet1, UserSet2, UserSet3 Parameters: any user definable Parameter
Acquisition Abort	Delay up to 15,0 msec

Vendor Specific Features

DSNU / PRNU (FPN)	Based on offset / gain per column
Correction	
High Dynamic Range (HDR)	Piecewise linear response, up to 90 dB
Burst Mode	16 full frame images with up to 66,6 fps
Chunk Info	FrameID, RegionID, Timestamp, CRC32
Temperature measurement	Internal sensor temperature range: 0 °C .. +85 °C, accuracy: ±1,0 °C

Factory Settings after Start-Up

Operation Mode	Free Running, overlapped mode
Analog Controls	Exposure Time: 4 msec, Gain: 0 dB, Offset: 0
Pixel Format	BayerGB8
Partial Scan	Off
Acquisition Frame Rate	Off
Timer	Off
Defect Pixel Correction	On
FPN Correction	On
Camera Link interface	2 tap Camera Link Base, 80 MHz
Digital Input	Line0, invert = false, trigger source = All
Digital Output	Line1/2/3, invert = false, line source = Off