

MV-SC7120PM-00C-NNN

12 MP Smart Camera



Introduction

MV-SC7120PM-00C-NNN smart camera is developed based on high-performance embedded platform. It adds vision algorithms like character recognition, object recognition, object sorting, etc. after integrating general vision algorithms. With mechanical autofocus function, the smart camera can meet different scenario demands. It can be easily configured and operated via the SCMVS client software, and uses Ethernet to output vision tool results and customized results.

Key Feature

- Built-in deep learning algorithms to achieve character and object recognition, object sorting, etc.
- Integrates general vision algorithms to achieve location, measurement, recognition, etc.
- Supports mechanical autofocus function to achieve fast debugging and configuration.
- Big memory and storage support image savings in loop with high performance.
- Adopts multiple I/O interfaces for controlling.
- Supports multiple communication protocols.
- Supports indicators displaying device status.

Available Model

MV-SC7120PM-00C-NNN

Applicable Industry

Consumer electronics, food and beverage, pharmaceutical, automobile, etc.

Dimension

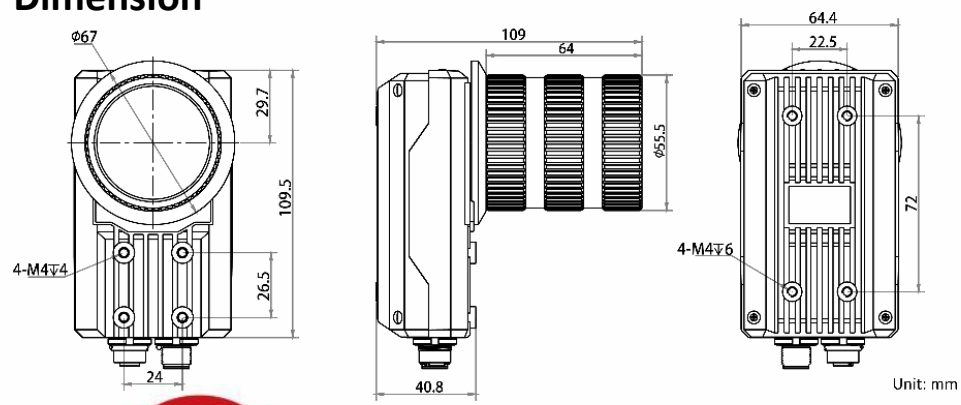

Specification

Model	MV-SC7120PM-00C-NNN
Tool	
Vision tool	<ul style="list-style-type: none"> ● Count: Pattern count, spot count, edge count ● Existence: Pattern existence, spot existence, edge existence, circle existence, line existence ● Location: Match location, match calibration ● Logic tool: If module, condition judge, logic judge, combination judge, string comparison, calculator ● Measurement: L2L angle, diameter measurement, brightness analysis, contrast measurement, width measurement, P2L measurement, greyscale size, line angle, edge width measurement ● Recognition: OCR, code recognition, DL classification, DL object detection
Solution capacity	Supports solution importing and exporting, up to 32 solutions and 40 modules can be stored.
Communication protocol	RS-232, TCP, UDP, FTP, Profinet, ModBus, EtherNet/IP
Camera	
Sensor type	CMOS, global shutter
Pixel size	3.2 μm × 3.2 μm
Sensor size	1"
Resolution	4096 × 3072
Max. frame rate	24 fps
Gain	0 dB to 15 dB
Exposure time	16 μs to 1 sec
Pixel format	Mono 8
Mono/color	Mono
Platform	
Memory	8 GB
Storage	32 GB
Electrical feature	
Data interface	Gigabit Ethernet interface
Digital I/O	12-pin M12 connector provides power and I/O, including opto-isolated input (Line 0/1/2) × 3, opto-isolated output (Line 3/4/5) × 3, and RS-232 × 1
Power supply	24 VDC
Power consumption	Approx. 7.5 W@24 VDC

Mechanical	
Lens mount	C-mount
Lens cap	Transparent lens cap
Light source	Not included
Indicator	Power indicator (PWR), network indicator (LNK/ACT), and user-defined indicator (U1/U2).
Dimension	109.5 mm × 64.4 mm × 109 mm (4.3" × 2.5" × 4.3")
Weight	Approx. 470 g (1.0 lb.)
Ingress protection	IP67 (under proper installation of waterproof lens cap)
Temperature	Working temperature: 0 °C to 50 °C (32 °F to 122 °F) Storage temperature: -30 °C to 70 °C (-22 °F to 158 °F)
Humidity	20% to 95% RH, non-condensing
General	
Client software	SCMVS
Certification	CE, FCC, KC

HIKROBOT

Hangzhou Hikrobot Technology Co., Ltd.
No.399 Danfeng Road, Binjiang District, Hangzhou 310051, China.
en.hikrobotics.com

Copyright Hikrobot

Hangzhou Hikrobot Technology Co., Ltd. All Rights Reserved. Hangzhou Hikrobot Technology does not tolerate any infringement. Any organization or individual may not imitate or reproduce in whole or in part of the content. The data herein is based on Hikrobot's internal evaluation. Actual data may vary depending on specific configuration and operating condition. The information herein is subject to change without notice. All the content has been checked conscientiously. Nevertheless, Hikrobot shall not be liable to damages resulting from errors, inconsistencies or omissions.